



About this document

This document contains screenshots of software available from Cheresources.com. You can find this title in our online store at:

<http://www.cheresources.com/invision/store/>

Clicking the above link should activate your default browser and launch the site.

We recommend using our search feature to find the title.

If you haven't visited our site before, you can find the main page at:

<http://www.cheresources.com>

Thanks for visiting our site,

Chris Haslego
President
Cheresources, Inc.

© COPYRIGHT, 2005. CHERESOURCES, INC.

1422 Goswick Ridge Road
Midlothian VA 23114

Fax: 561-658-6489
Email: support@cheresources.com

*Content Based
Chemical Engineering*

MAP - Stress & Deflection - Rectangular Plate, with Stiffeners

SERVICE:

----- **Plate** -----

- Longest Side : in. (L)
- Shortest Side : in. (H)
- Ratio of H/L :
- Ratio of H/L : Factor, α
- Ratio of H/L : Factor, β
- Plate Thickness : in.
- Corrosion Allowance : in.
- Actual Thickness : in. (t)
- Allowable Stress : psi (S)

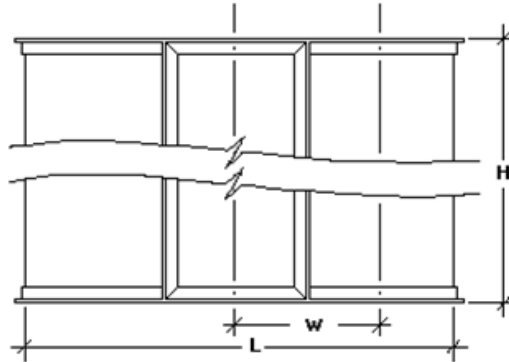

----- **Panel** -----

- Panel Width : in. (w)
- Section Modulus of Stiffeners : in.³ (Z)

----- **MAP Calculation** -----

$$MAP := \left(\frac{Z}{0.0642 w \cdot H^2} \right) \cdot S = \quad \text{psi}$$

MAP - Stress & Deflection - Rectangular Plate, with Stiffeners

SERVICE:

----- **Plate** -----

- Longest Side : mm (L)
- Shortest Side : mm (H)
- Ratio of H/L :
- Ratio of H/L : Factor, α
- Ratio of H/L : Factor, β
- Plate Thickness : mm
- Corrosion Allowance : mm
- Actual Thickness : mm (t)
- Allowable Stress : kPa (S)

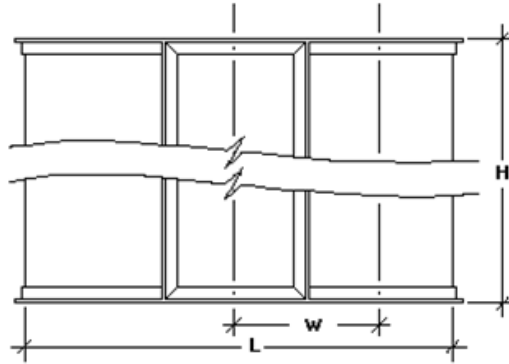

----- **Panel** -----

- Panel Width : mm (w)
- Section Modulus of Stiffeners : mm³ (Z)

----- **MAP Calculation** -----

$$MAP := \left(\frac{Z}{0.0642 w \cdot H^2} \right) \cdot S = \quad \text{kPa}$$

MAP/MAV - Stress & Deflection - Rectangular Plate, full edge support

BASIS : This program is for internal and external pressure on a Rectangular Plate when the Section Modulus of the stiffeners is known. Options allow calculation for the top, side and bottom plates of a vessel. The MAV calculation subtracts the dead load of the plate (W/A) from the top segment.

NOTE : Always begin a new case by retrieving the original file. Direct entry of data in cells that originally contain table lookups could cause functions to be lost and/or incorrect calculations. Cells that require data entry are colored **RED**; calculated values are black.

REFERENCES :

- 1) *A method for designing rectangular storage tanks.* - Kanti K. Mahajan
Chemical Engineering - March 28, 1977
- 2) *Pressure Vessel Handbook - 11th Edition*
- 3) *Manual of Steel Construction - Allowable Stress Design - A.I.S.C. 9th Edition*

◇-◇-◇-◇-◇ ProcSafety May 2011, by Mark Roote ◇-◇-◇-◇-◇

The originator of these spreadsheets specifically excludes all warranties, expressed or implied, as to the accuracy of the data and other information set forth and assumes NO liability for any losses or damage resulting from the use of the materials or application of the data.

Consistent with GOOD ENGINEERING PRACTICE, the burden rests with the USER of these spreadsheets to review ALL calculations and assumptions. The USER IS FULLY RESPONSIBLE for the results or decisions based on calculations.

procsafety@rooteshome.com