

Explanation of the calculations behind the sheet

(revised edition)

By André de Lange

Heat tracing is used to prevent heat loss from process fluids being transported in process fluid pipes, when there is risk of damage to piping, or interference with operation such as fouling or blockage, caused by the congealing, increase in viscosity, or separation of components in the fluid below certain temperatures, or when there is risk of formation of corrosive substances or water due to condensation in corrosive services. This prevention of heat loss is accomplished by employing electrical tracing or steam tracing, and insulating both the process fluid pipe and the tracer together, using appropriate insulation lagging, in an attempt to minimise heat loss from the pipe and tracer to their surroundings.

Steam tracing is described by attaching a smaller pipe containing saturated steam, also known as the “tracer”, parallel to the process fluid pipe. The two pipes are then also insulated together with the specified insulation and jacketed if necessary. Steam tracing is more labor intensive to install than electrical heat tracing, but there are very few risks associated with it. The temperature of the tracer also cannot exceed the maximum saturation temperature of the steam, as it operates at specific steam pressures.

Steam tracing may be done in one of two ways. Bare steam tracing is the most popular choice as it is fairly easily installed and maintained and it is ideally suited to lower temperature requirements. It is simply composed of a half inch or three quarters of an inch pipe containing saturated steam attached to the process fluid pipe by straps and both pipes are then insulated together. The other available option is to make use of cemented steam tracing, during which heat conductive cement is placed around the steam tracer running parallel to the process fluid pipe, (shown in figure 1b), in an attempt to increase the contact area available for heat transfer, between the tracer and the process fluid pipe.

Because the area around the process fluid pipe and tracer cannot be accurately described simply by assuming perfect cylindrical geometry, provision had to be made for a realistic impression of the true geometry. (See figures 1a and 1b)

Fig. 1a: Bare Tracer

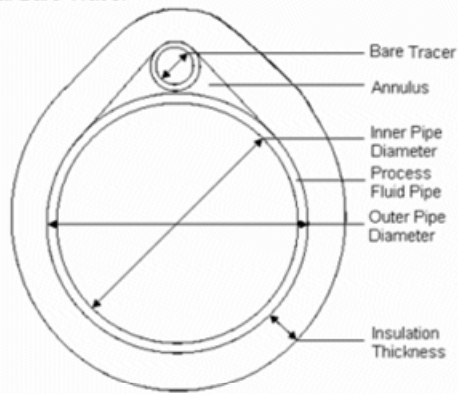
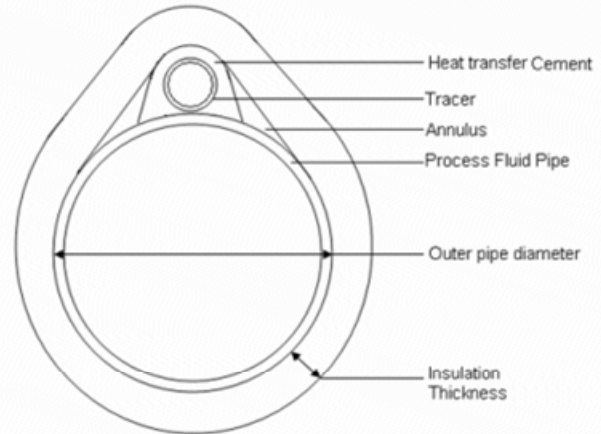

Fig.1b:Cemented Tracer



For bare tracing, the following formulas were derived: The calculations for the cemented tracer are not shown, but are derived from the same principles

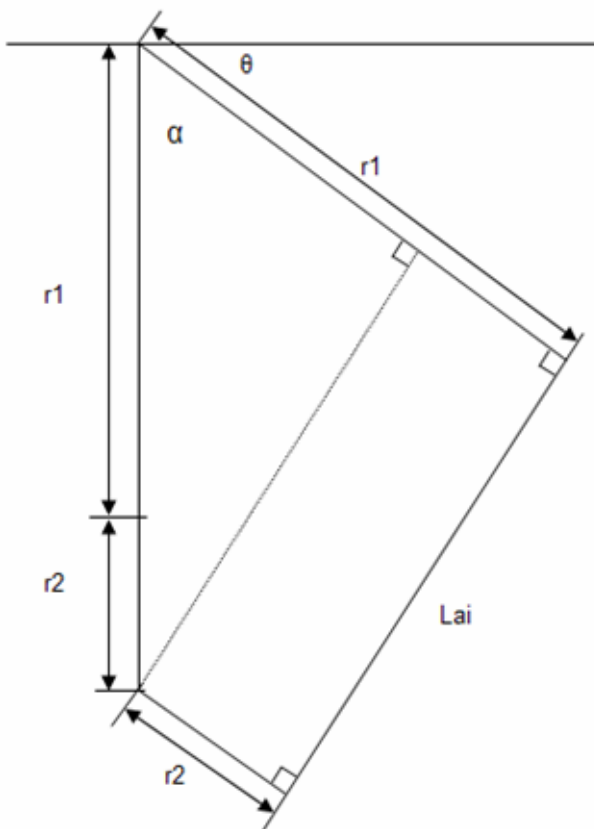

Figure 2: Schematic diagram to calculate L_{ai}

$$\alpha = \cos^{-1} \left(\frac{r_1 - r_2}{r_1 + r_2} \right)$$

$$\tan \alpha = \frac{L_{ai}}{(r_1 - r_2)}$$

$L_{ai} = (r_1 - r_2) \tan \alpha$ with $2L_{ai}$ being the area of annulus space exposed to insulation per metre of pipe length, and r_1 and r_2 being the outer diameters of the process fluid pipe and the steam tracer pipe, respectively.

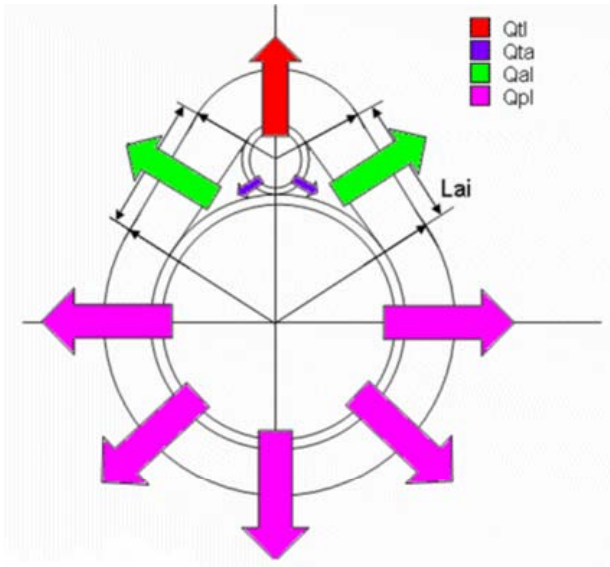

Figure 3a: Heat loss from a bare tracer

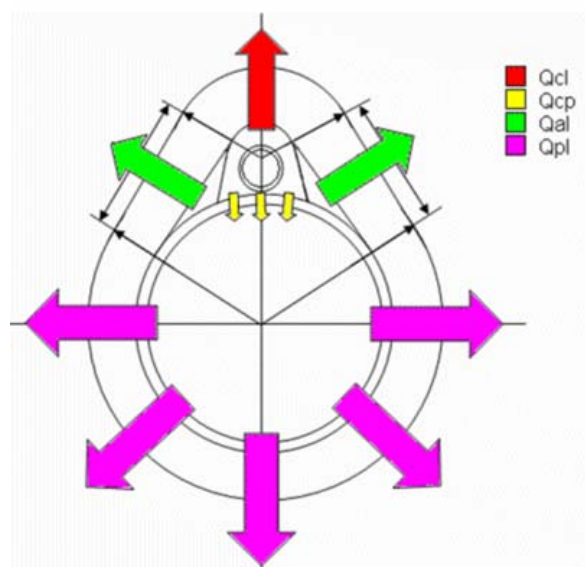

Figure 3b: Heat loss from a cemented tracer

Q in with tracer = Q lost in total

$$Q_{ta} + Q_{tl} = Q_{tl} + Q_{al} + Q_{pl}$$

$$\therefore Q_{ta} = Q_{al} + Q_{pl}$$

Area of tracer in contact with annulus (top part in following diagram)

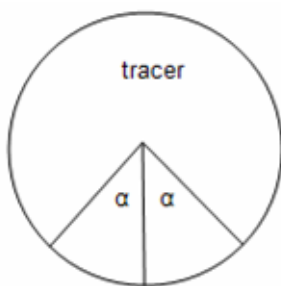

Figure 4: Schematic diagram of tracer

$$\text{Circumference} = 2\pi r_2$$

$$\text{Exposed area } (S) = (2\pi - 2\alpha)r_2$$

$$S = 2r_2(\pi - \alpha)$$

If there are n tracers and pipe length = L :

$$A_{ta} = nSL = 2nr_2(\pi - \alpha)$$

Area of annulus in contact with insulation

$$A_{al} = 2nL L_{ai}$$

Area of process fluid pipe in contact with insulation (top part of following figure)

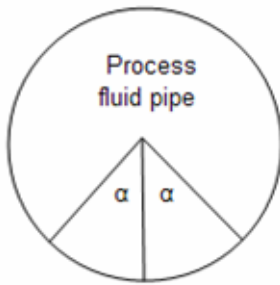

A log-mean area with correction factor was used, since the insulation will still touch the pipe between tracers.

$$A_{pl} = (2\pi - (1.25 + 0.75n)\alpha) \left(\frac{r_{insulation} - r_{inner}}{\ln\left(\frac{r_{insulation}}{r_{inner}}\right)} \right) L$$

Figure 5: Schematic diagram of process fluid pipe

$$Q_{ta} = h_c A_{ta} (T_s - T_{ann})$$

$$h_c = 1.18 \left[\frac{T_s - T_{ann}}{2r_2} \right]^{\frac{1}{4}} \text{ (W/mK) with T in K and } r_2 \text{ in m.}$$

$$h_c = 0.377922 \left[\frac{T_s - T_{ann}}{r_2} \right]^{\frac{1}{4}} \text{ (BTU/h ft } ^\circ\text{F) with T in } ^\circ\text{F and } r_2 \text{ in inches.}$$

$$Q_{al} = \frac{A_{al}(T_{ann} - T_{surf})}{\left[\frac{\text{Insthick}}{k_{ins}} + \frac{1}{h_o} \right]}$$

$$Q_{pl} = \frac{L(T_p - T_{amb})(2\pi - (1.25 + 0.75n)\alpha)}{\left[\frac{\ln\left(\frac{r_1}{r_{1(inner)}}\right)}{k_w} + \frac{\ln\left(\frac{r_{ins}}{r_1}\right)}{k_{ins}} + \frac{1}{h_o r_{ins}} \right]}$$

$$h_o = \frac{q}{A_{\log mean}(T_{surf} - T_{amb})}$$

$$q = \left[\left(0.548\varepsilon \left[\left(\frac{T_{surf}}{55.55} \right)^4 - \left(\frac{T_{amb}}{55.55} \right)^4 \right] \right) + \left[\left(1.957(T_{surf} - T_{amb})^{5/4} \right) \left(\sqrt{2.85V_m + 1} \right) \right] \right]$$

W/m²

(was also adapted in the spreadsheet to be in units of BTU/hft²)

$$T_{surf, low} = T_p - q \left[\frac{r_{ins} \ln\left(\frac{r_{ins}}{r_1}\right)}{k_{ins}} \right]$$

$$T_{surf, hottest} = T_{st} - q \left[\frac{(r_2 + insthick) \ln\left(\frac{r_2 + insthick}{r_2}\right)}{k_{ins}} \right]$$

It was assumed that 80% of the surface temperature is contributed by $T_{surf, low}$, the surface temperature on the process fluid side of the pipe, and 20% of the surface temperature is contributed by the surface temperature on the steam line side of the pipe, which is also the hottest surface temperature.

Calculating steam consumption

$$Q = m \overline{C_p} \Delta T$$

$$= m \Delta H_{latent}$$

$$\therefore m = Q / \Delta H_{latent}$$

$$Q = Q_{il} + Q_{al} + Q_{pl}$$

Appendix 1 : Derivations of Formulas

Bare Tracing Geometry

Fig A1 Geometric analysis of bare tracer

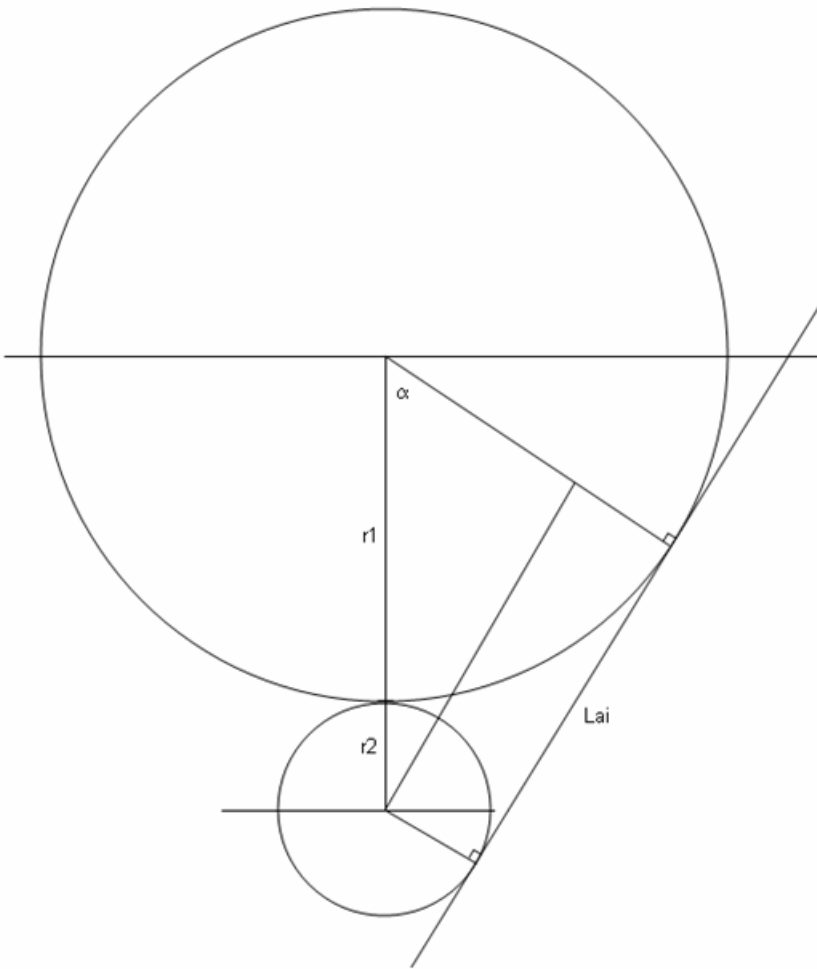

$$\alpha = \cos^{-1} \left(\frac{r_1 - r_2}{r_1 + r_2} \right)$$

$$\tan \alpha = \frac{L_{ai}}{r_1 - r_2}$$

$$\therefore L_{ai} = (r_1 - r_2) (\tan \alpha)$$

Energy added by tracer \equiv Energy lost by system: Refer again to Fig. 3a.

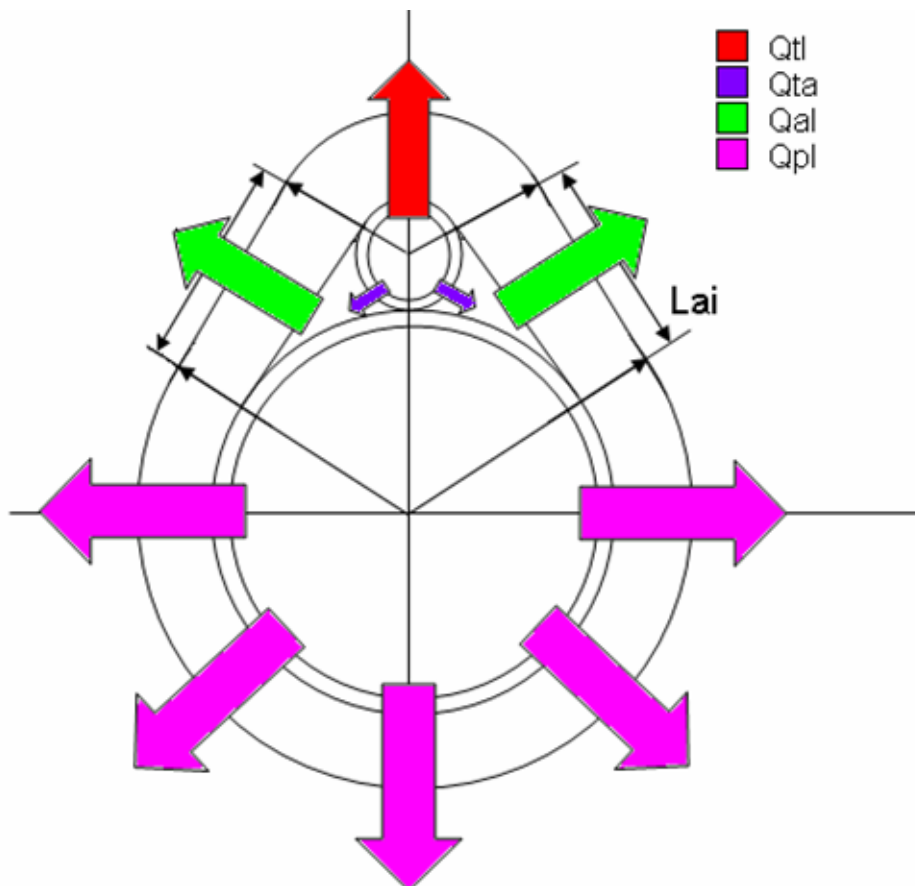

Fig. 3a Bare Tracer

The movement of energy across the system boundaries may be explained as follows:

$$\therefore Q_{ta} + Q_{tp} + Q_{tl} = Q_{il} + Q_{al} + Q_{pl}$$

$$Q_{tp} \approx 0 \quad (\text{Insufficient area for heat transfer})$$

$$\therefore Q_{ta} = Q_{al} + Q_{pl}$$

Fig. A2 Different areas of the system

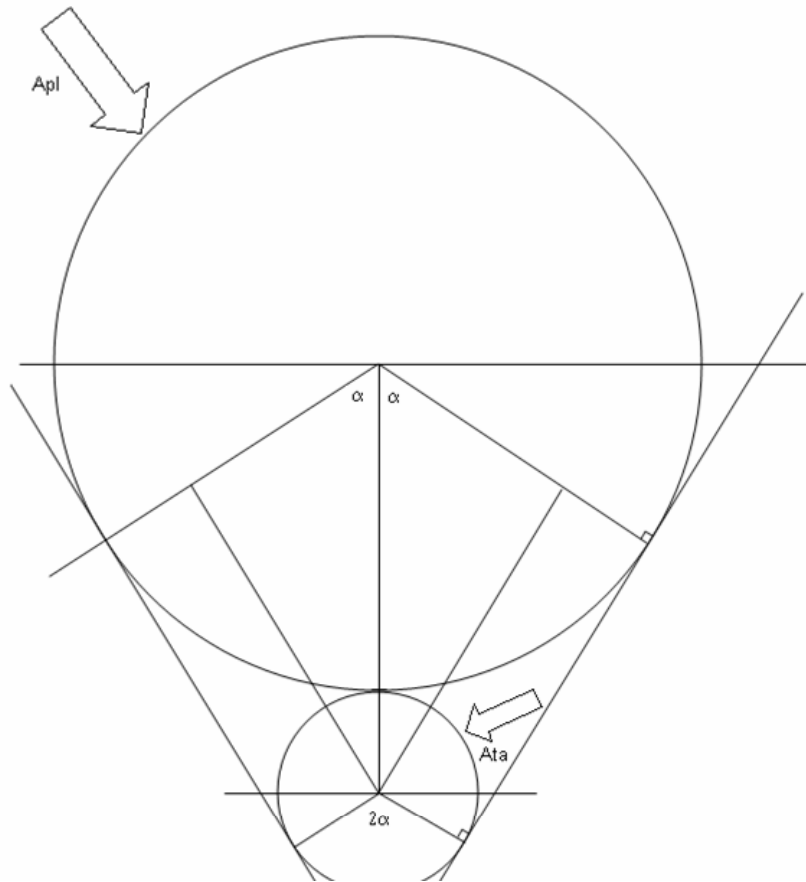

$$A_{ta} = 2nLr_2(\pi - \alpha)$$

$$A_{al} = 2nL(r_1 - r_2)(\tan \alpha)$$

$$A_{pl} = (2\pi - (1.25 + 0.75n)\alpha)L \left(\frac{r_{ins} - r_1}{\ln \left(\frac{r_{ins}}{r_1} \right)} \right)$$

The term $(1.25+0.75n)$ is used as a correction factor for the angle that the process fluid has that corresponds to the ambient air, when more than 1 tracer is used, otherwise the area would soon decrease to 0 with 3 or more tracers. This is a valid correction, when one keeps in mind that the insulation lagging “folds” over the pipes. See figure A3.

Fig A3: Validation for correction factor

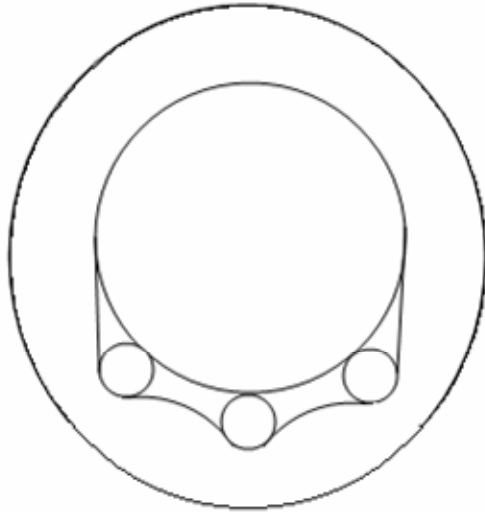

The convection heat transfer coefficient for the annulus (still air) is given by

$$h_c = 1.18 \left[\frac{T_s - T_{ann}}{2r_2} \right]^{1/4} \quad \text{Le Roux, D.F. (1997) "Thermal Insulation and Heat$$

Tracing", Guideline presented by line manager D.F. le Roux, Secunda.

The remaining design equations for bare tracing are given in section 4.:Results and Discussion.

Cemented Tracing Geometry

Fig A4: Geometric Analysis of Cemented Tracer

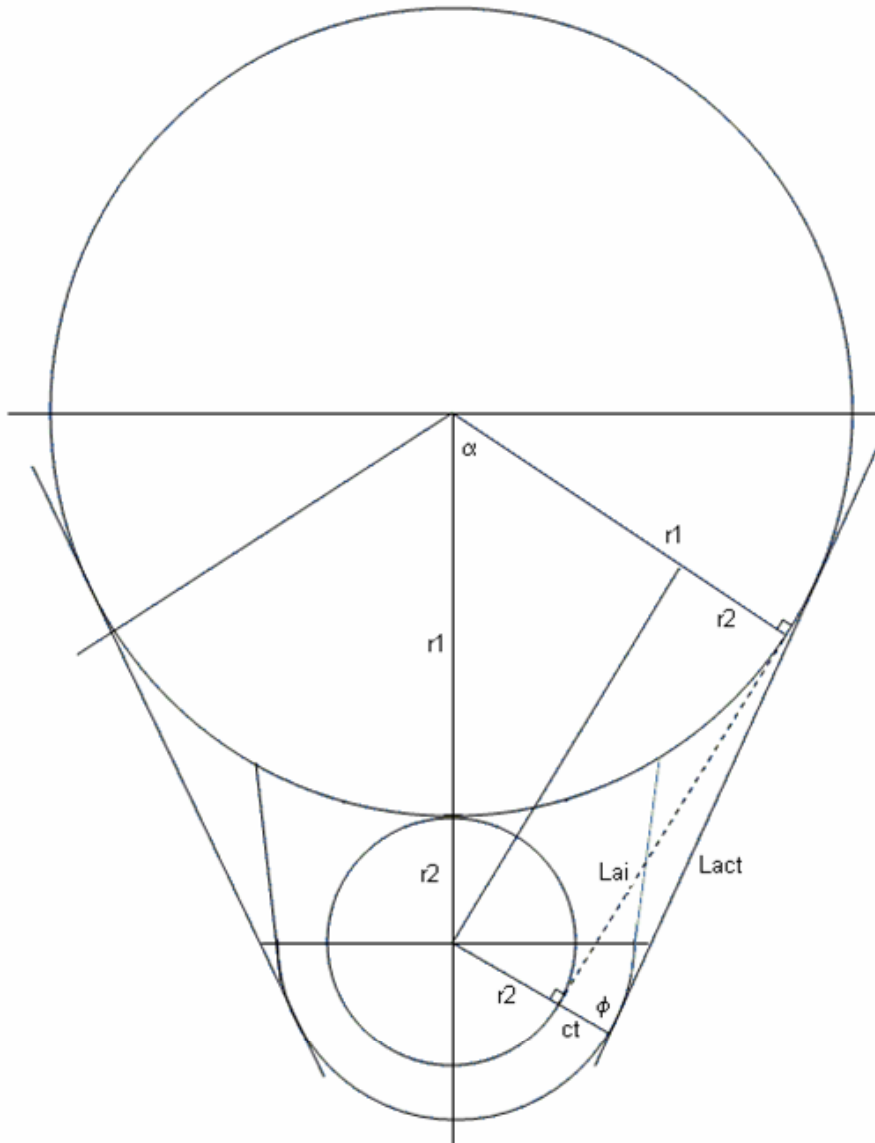

$$\alpha = \cos^{-1} \left(\frac{r_1 - r_2}{r_1 + r_2} \right)$$

$$\sin \phi = \frac{L_{ai}}{L_{act}}$$

$$\tan \phi = \frac{L_{ai}}{c_t}$$

$$\therefore L_{act} = \frac{\tan \alpha (r_1 - r_2)}{\sin \left(\tan^{-1} \left[\frac{\tan \alpha (r_1 - r_2)}{c_t} \right] \right)}$$

Energy added by tracer \equiv Energy lost by system: Refer again to Fig. 3b.

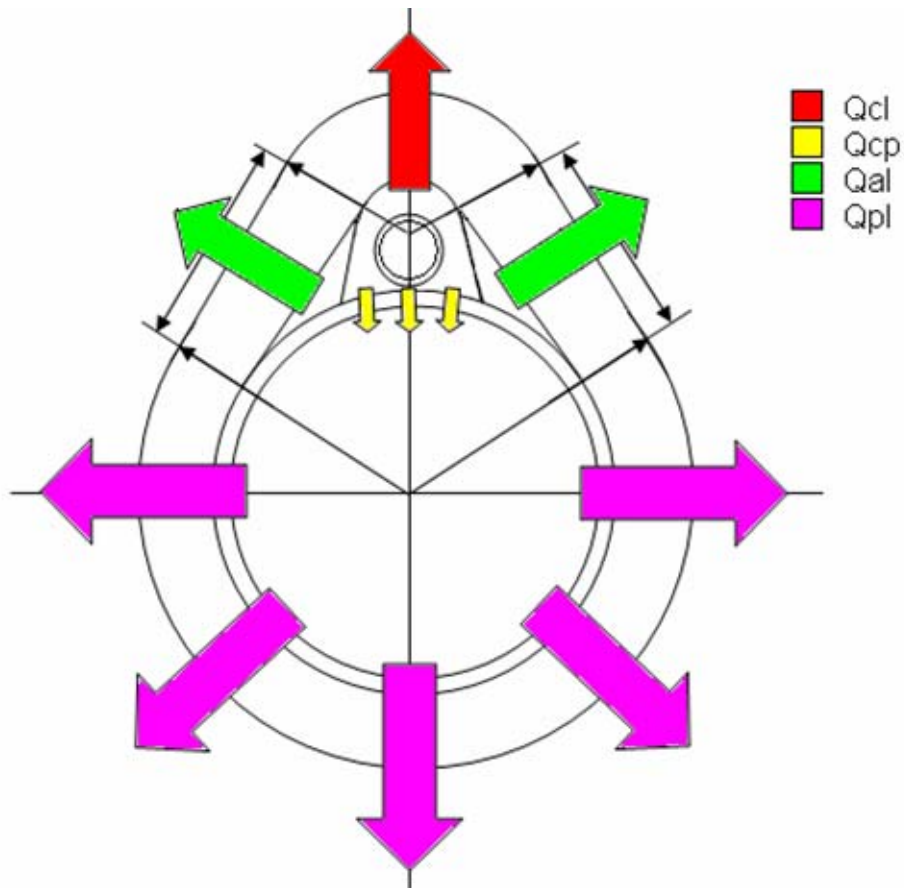

Fig. 3b Cemented Tracer

The energy movement across the system boundaries may be explained as follows:

$$Q_{ca} + Q_{cp} + Q_{cl} = Q_{cl} + Q_{al} + Q_{pl}$$

$$Q_{ca} + Q_{cp} = Q_{al} + Q_{pl}$$

$$A_{ca} = nL(0.2357Dt - 2\alpha(r_2 + c_i))$$

$$A_{cp} = 4nLr_2 \quad \text{Molloy, J.F., Fundamentals of Heat Transfer, p72 – 101}$$

$$A_{pl} = L \left(\frac{r_{ins} - r_1}{\ln\left(\frac{r_{ins}}{r_1}\right)} \right) (2\pi - (1.25 + 0.75n)\alpha)$$

The remaining equations are given in section 4:Results and Discussions.

Appendix 2 : Table of q_t vs. NPS

Table 3. q_t vs. NPS	
NPS	q_t (W/m ² K)
½"	60.2879608
¾"	60.2879608
1"	60.1127051
1½"	60.1127051
2"	57.1333582
2½"	54.329267
3"	50.9994087
3½"	48.7210846
4"	47.1437833
6"	41.7108566
8"	37.6799755
10"	32.2470488
12"	25.5873322
14"	21.3811954
16"	17.1750586
18"	17.1750586
20"	17.1750586
24"	16.9998029
30"	16.9998029
36"	16.9998029
42"	16.8245472
48"	16.8245472